

Clutch

Table of Contents

Exploded View	5-2
Specifications	5-3
Special Tools	5-3
Clutch	5-4
<i>Clutch Lever Play Inspection</i>	5-4
<i>Clutch Lever Play Adjustment</i>	5-4
<i>Clutch Cable Removal</i>	5-5
<i>Clutch Release Removal Note</i>	5-5
<i>Clutch Disassembly</i>	5-5
<i>Clutch Assembly</i>	5-6
<i>Friction Plate Wear, Damage Inspection</i>	5-7
<i>Friction or Steel Plate Warp Inspection</i>	5-8
<i>Clutch Spring Free Length Measurement</i>	5-8
<i>Clutch Housing Finger Inspection</i>	5-8
<i>Clutch Hub Spline Inspection</i>	5-8
Primary Gear, Clutch Gear	5-8
<i>Primary Gear and Clutch Gear Removal</i>	5-8
<i>Primary Gear Installation</i>	5-9
<i>Primary Gear Timing Procedure</i>	5-10
<i>Primary Gear Disassembly</i>	5-11
<i>Primary Gear Assembly</i>	5-11
<i>Primary Gear Damper Inspection</i>	5-13
Kickstarter	5-13
<i>Kickstarter Removal</i>	5-13
<i>Kickstarter Installation</i>	5-13
<i>Kickstarter Assembly Notes</i>	5-14
<i>Kick Lever Installation</i>	5-14
Right Engine Cover	5-15
<i>Right Engine Cover Cleaning</i>	5-15
<i>Spring Pin Assembly Note</i>	5-15
<i>Cover Damper Installation</i>	5-15
Clutch Cover	5-15
<i>Clutch Cover Installation</i>	5-15
Clutch Cable	5-16
<i>Clutch Cable Installation</i>	5-16

5-2 CLUTCH

Exploded View

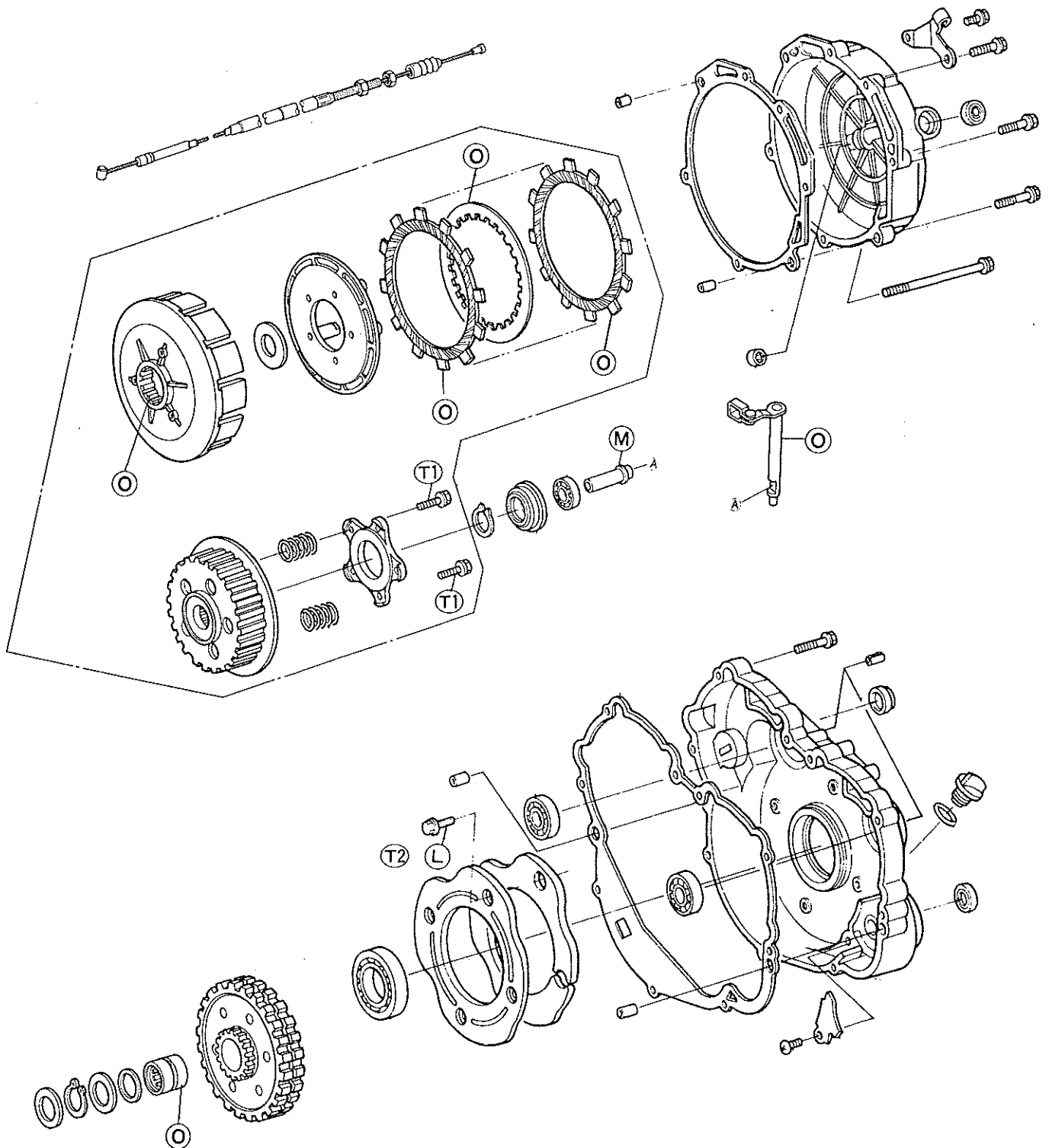

- T1: 8.8 N-m (0.9 kg-m, 78 in-lb)
T2: 9.8 N-m (1.0 kg-m, 87 in-lb)
L : Apply a non-permanent locking agent.
M : Apply a molybdenum disulfide grease.
O : Apply transmission oil to the surface.

.....
Specifications
.....

Item	Standard	Service Limit
Clutch:		
Clutch lever free play	0.5 to 1.0 mm	— — —
Clutch spring free length	34.6 – 36.0 mm	34.2 mm
Friction plate thickness	2.9 – 3.1 mm	2.7 mm
Friction and steel plate warp	not more than 0.2 mm	0.3 mm

.....
Special Tools
.....

Circlip Pliers: 57001-144

Bearing Driver: 57001-1160

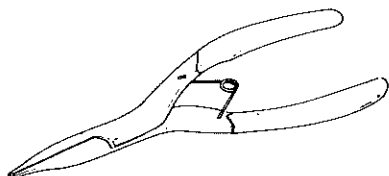

5-4 CLUTCH

Clutch

Due to friction plate wear and clutch cable stretch over a long period of use, the clutch must be adjusted in accordance with the Periodic Maintenance Chart.

WARNING

○To avoid a serious burn, never touch the engine or exhaust pipe during clutch adjustment.

Clutch Lever Play Inspection

- Check that the clutch lever has 0.5 to 1.0 mm of play as shown in the figure.
- ★If the check reveals improper play, adjust the clutch.

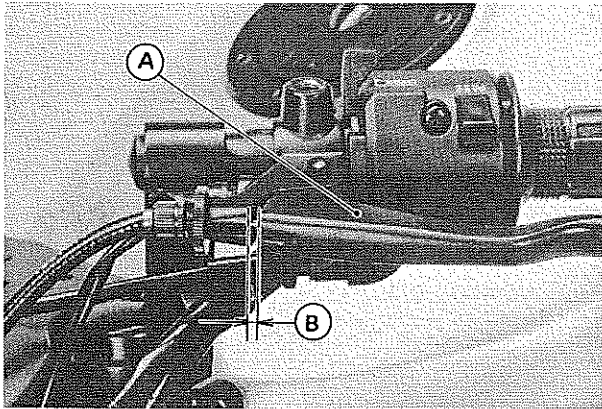

A. Clutch Lever B. Play

Clutch Lever Play Adjustment

- Loosen both adjuster nuts at the clutch cover as far as they will go.

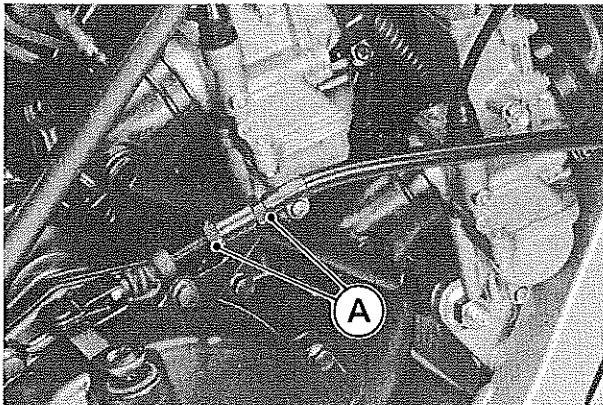

A. Adjuster Nuts

- Loosen the locknut at the clutch lever.
- Turn the adjuster so that 5 to 6 mm of threads are visible.

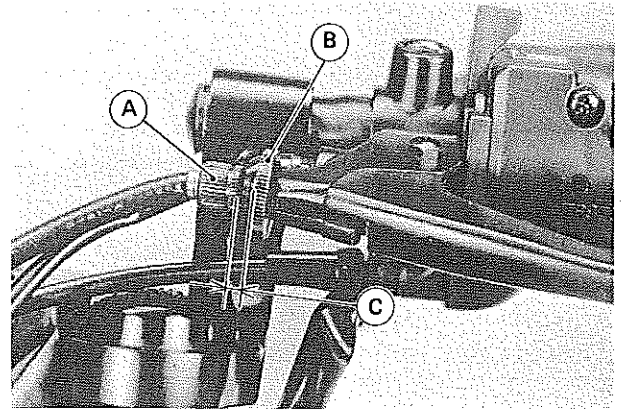

A. Adjuster C. 5 to 6 mm
B. Locknut

- Pull the clutch cable tight and tighten the adjuster nuts against the bracket.

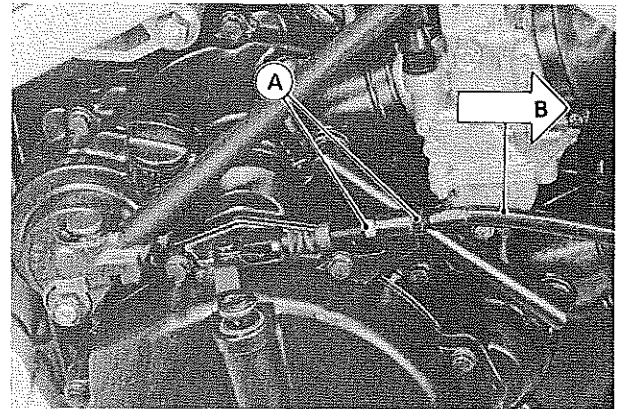

A. Adjuster Nuts B. Pull the clutch cable

- Turn the adjuster at the clutch lever until the free play is correct.

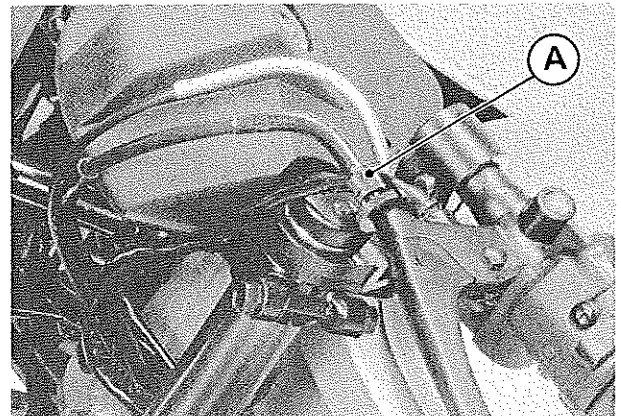

Clutch Lever Free Play
0.5 to 1.0 mm

- Tighten the locknut at the clutch lever.

NOTE

○Be sure that the outer cable end at the clutch lever is fully seated in the adjuster at the clutch lever, or it could slip into the place later, creating enough cable play to prevent clutch disengagement.

●After the adjustment is made, start the engine and check that the clutch does not slip and that it releases properly.

Clutch Cable Removal

- Slide the dust cover at the clutch cable lower end out of place.
- Loosen the nuts, and slide the lower end of the clutch cable to give the cable plenty of play.
- Loosen the knurled locknut at the clutch lever, and screw in the adjuster.
- Line up the slots in the clutch lever, knurled locknut, and adjuster, and then free the cable from the lever.

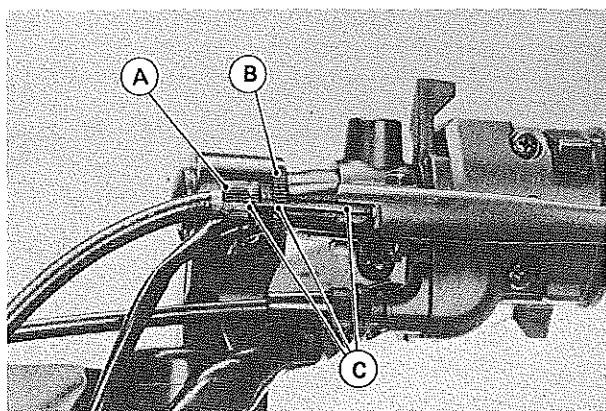

A. Adjuster C. Slot
B. Knurled Locknut

●Free the clutch inner cable tip from the clutch release lever.

Clutch Release Removal Note

●Remove the clutch cover, and then pull the clutch release shaft out of the cover.

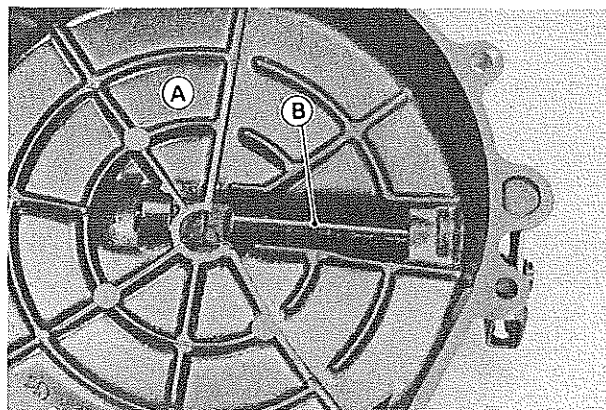

A. Clutch Cover
B. Clutch Release

Clutch Disassembly

- Remove the clutch cable lower end.
- Remove the clutch cover.
- ★If the clutch springs, friction plates or steel plates are to be disassembled, remove the clutch spring bolts.

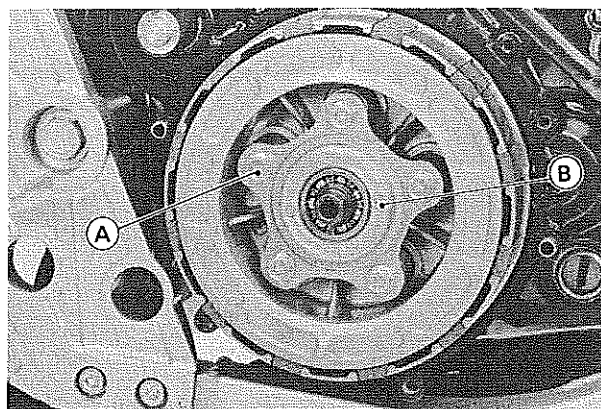

A. Clutch Spring Bolt B. Bearing Holder

NOTE

○It is not necessary to remove the clutch spring bolts for clutch assembly removal.

●Remove the bearing holder and then the circlip.

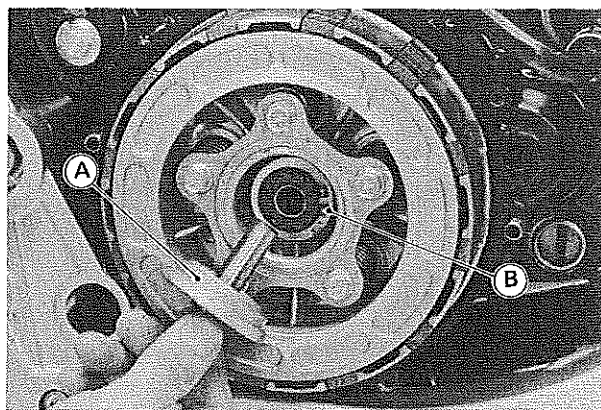

A. Bearing Holder B. Circlip

●Remove the clutch hub and the clutch plates.

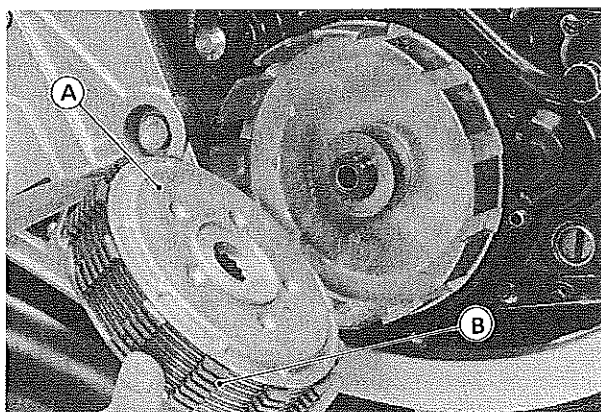

A. Clutch Hub B. Clutch Plates

5-6 CLUTCH

- Pull out the clutch housing.
- ★ If the clutch housing is hard to remove, pull it out using three bolts ($\phi 8$ mm x L20 mm). Screw the three bolts in the housing evenly.

CAUTION

- Use the round end or the dog point bolts to prevent right engine cover damage.

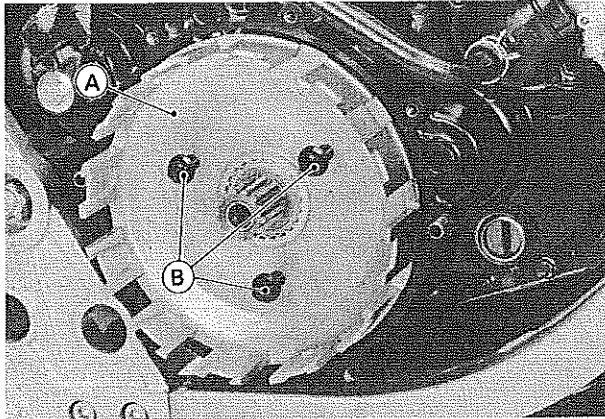

A. Clutch Housing B. Bolts

Clutch Assembly

- Install the right engine cover.

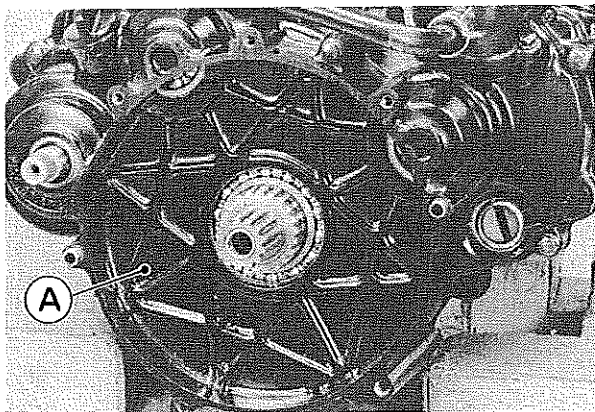

A. Right Engine Cover

- After inserting the clutch housing, install the thrust washer ($\phi 47 \times \phi 25.5 \times t2.5$).
- ★ If the clutch housing is hard to install, push it in evenly using the bearing driver (special tool) until the clutch housing end is recessed 0.1 – 0.3 mm from the clutch gear end.

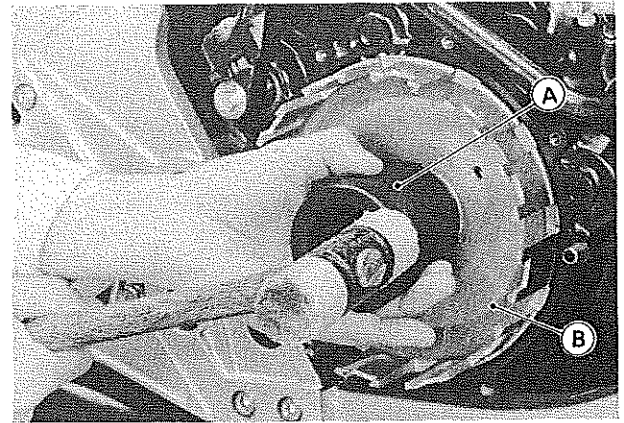

A. Bearing Driver: 57001-1160 B. Clutch Housing

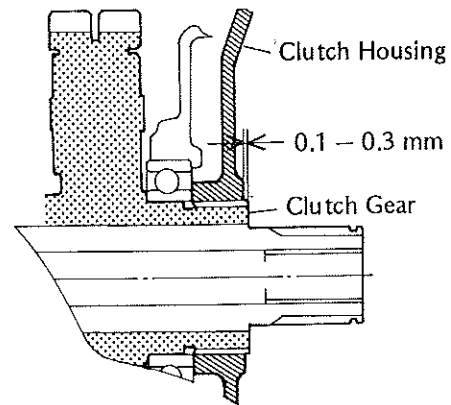

CAUTION

- Do not push the clutch housing in too strong. This could cause improper disengaging in clutch.
- Install the friction plates and steel plates, starting with a friction plate and alternating them.
- The grooves on the friction plate surfaces are cut tangentially and radially, install the friction plates so that the grooves run toward the center in the direction of the clutch housing rotation (counterclockwise viewed from the engine right side)

Friction Plate Installation

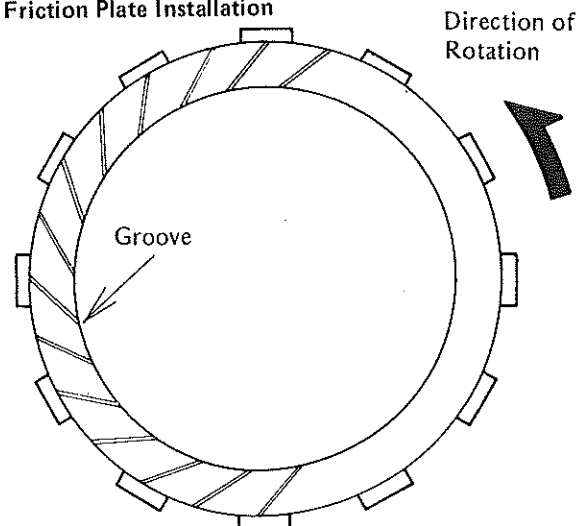

CAUTION

○If new dry steel plates and friction plates are installed, apply engine oil to the surfaces of each plate to avoid clutch plate seizure.

●After installing the clutch springs, tighten the clutch spring bolts fingertight while compressing the holder.

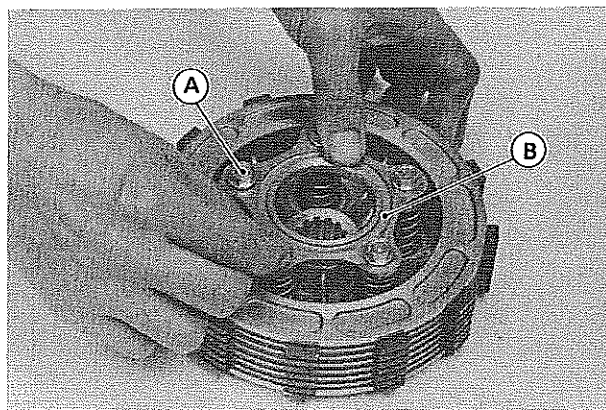

A. Clutch Spring Bolt B. Holder

○Install the clutch hub assembly while hand turning the shaft a little at a time in order to fit the splines. Do not force the clutch hub in order to prevent the hub spline damage.

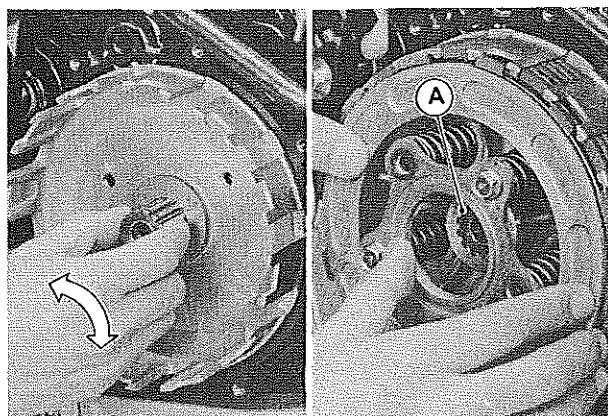

A. Clutch Hub

NOTE

○First, install the six friction plates fitting the tangs of plates in the grooves A in the clutch housing. And then, install the last one fitting the tangs in the grooves B in the housing.

- Then, tighten the clutch spring bolts to the specified torque.
- Discard the used clutch hub circlip, and install a new one.
- Install the clutch spring plate pusher, applying a molybdenum disulfide grease to the surface.

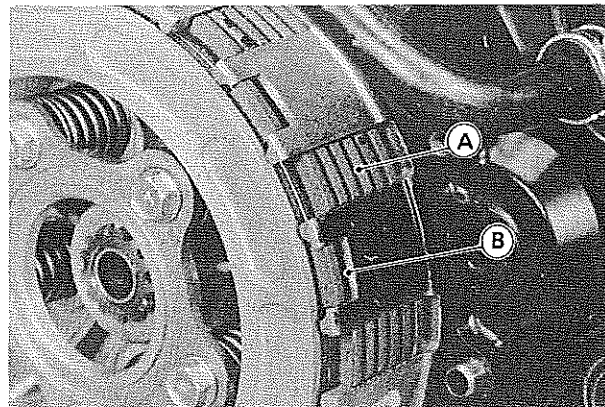

A. Groove A B. Groove B

Friction Plate Wear, Damage Inspection

- Visually inspect the friction plates to see if they show any signs of seizure, overheating, or uneven wear.
- ★If any plates show signs of damage, replace the friction plates and steel plates as a set.

Friction Plate Thickness Measurement

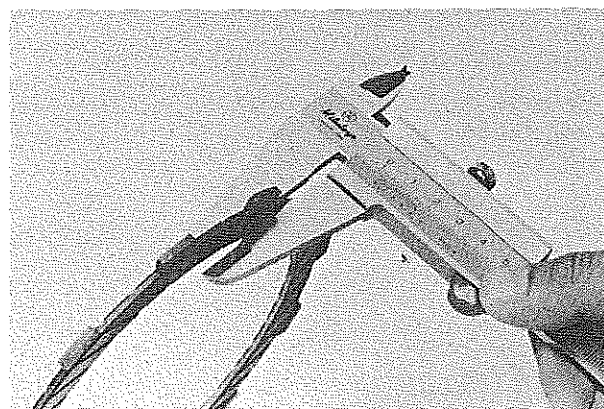

Friction Plate Thickness

Standard	2.9 – 3.1 mm
Service Limit	2.7 mm

5-8 CLUTCH

Friction or Steel Plate Warp Inspection

- Place each friction plate or steel plate on a surface plate, and measure the gap between the surface plate and each friction plate or steel plate. The gap is the amount of friction or steel plate warp.
- ★ If any plate is warped over the service limit, replace it with a new one.

Friction and Steel Plate Warp

Standard:	less than 0.2 mm
Service Limit:	0.3 mm

Friction and Steel Plate Warp Measurement

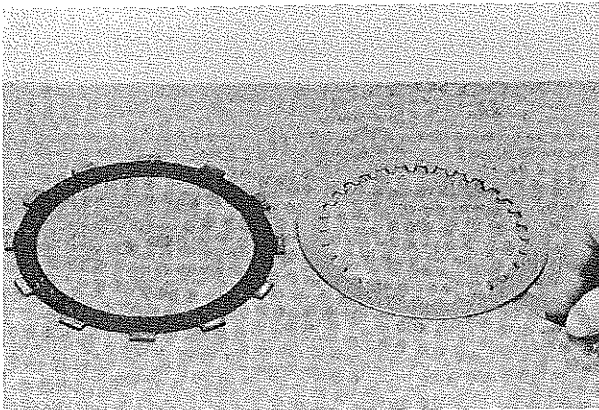

Clutch Housing Finger Inspection

- Visually inspect the fingers of the clutch housing where the tangs of the friction plates hit them.
- ★ If they are badly worn or if there are grooves cut where the tangs hit, replace the housing. Also, replace the friction plates if their tangs are damaged.

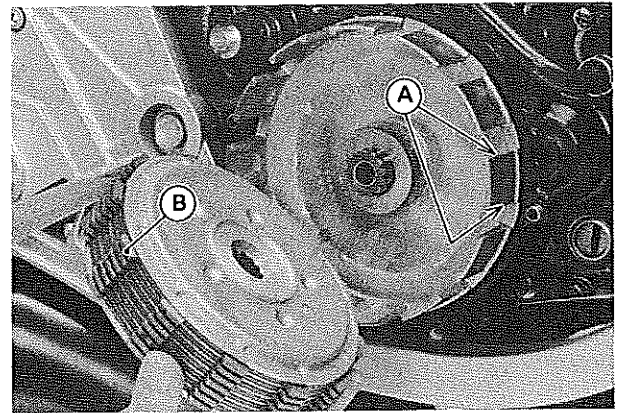

A. Clutch Housing Finger B. Friction Plate Tang

Clutch Hub Spline Inspection

- Visually inspect where the teeth on the steel plates wear against the splines of the clutch hub.
- ★ If there are notches worn into the splines, replace the clutch hub. Also, replace the steel plates if their teeth are damaged.

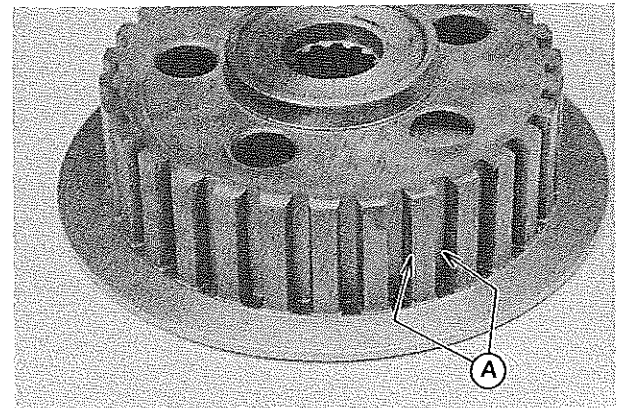

A. Clutch Hub Spline

Clutch Spring Free Length Measurement

Clutch Spring Free Length

Standard	34.6 – 36.0 mm
Service Limit	34.2 mm

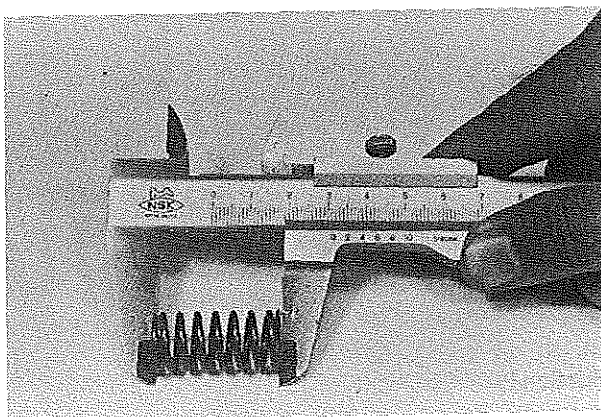

Primary Gear, Clutch Gear

Primary Gear and Clutch Gear Removal

- Remove the carburetors (see Fuel System).
- Remove the clutch.
- Remove the kick lever assembly by taking off the mounting nut.
- Remove the right engine cover.

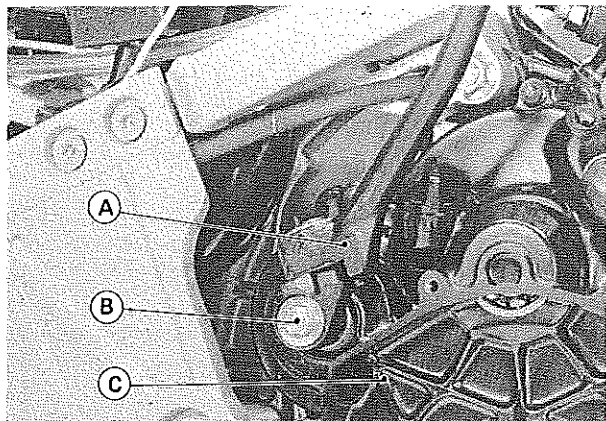

A. Kick Lever Assembly C. Right Engine Cover
B. Nut

● Remove the clutch gear.

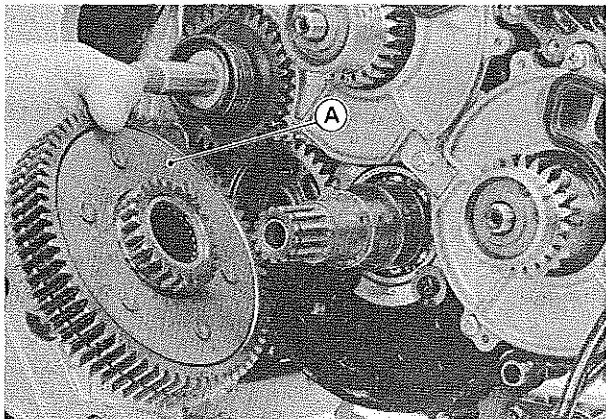

A. Clutch Gear

● Pull out the primary gears (with a built-in damper).

NOTE

○ It is not necessary to remove the primary gear circlips for primary gear removal.

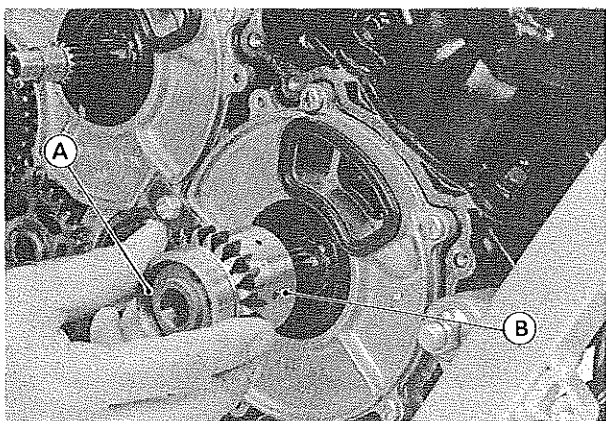

A. Circlips B. Primary Gears

Primary Gear Installation

● Be sure to install the front and rear crankshaft O-rings.

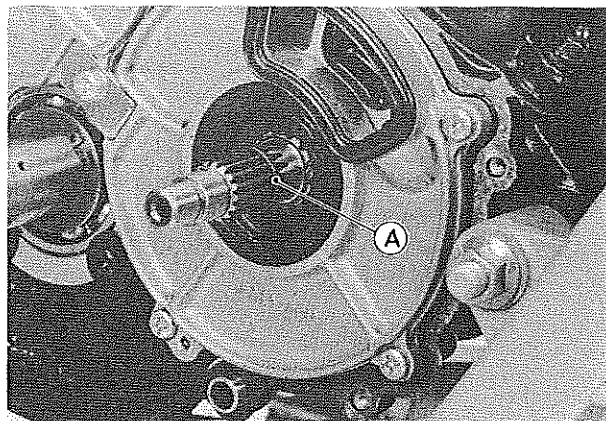

A. O-ring

NOTE

○ The front and rear primary gears have different gear positions as shown. Be careful not to mix up these gears.

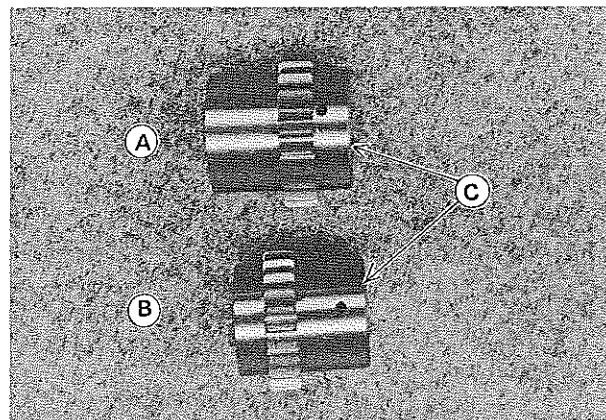

A. Front Primary Gear C. Large Chamfered End
B. Rear Primary Gear

● Before installing the primary gears, check to see that the damper cam punch mark is visible through the location hole.

★ If the mark is not visible, align the punch mark with a hole on the extension of the line mark (see Primary Gear Assembly).

Punch Mark

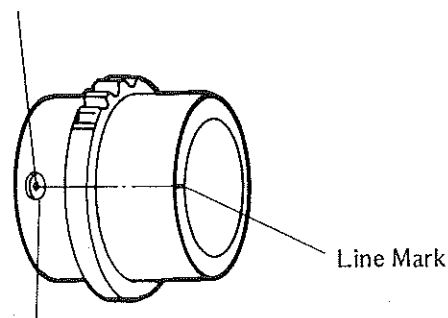

Location Hole

Line Mark

5-10 CLUTCH

Primary Gear Timing Procedure

- Install the rear primary gear with the teeth located inboard.

CAUTION

- Install each primary gear while hand turning it in order to prevent the oil seal lip damage.

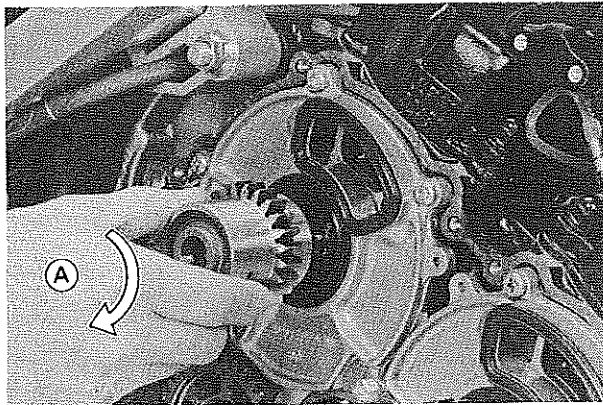
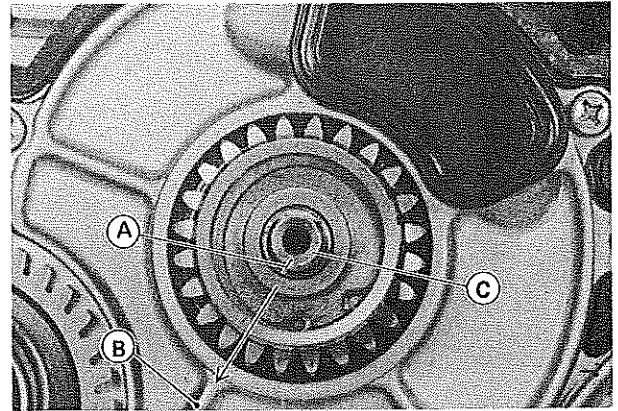

A. Hand turn the primary gear.

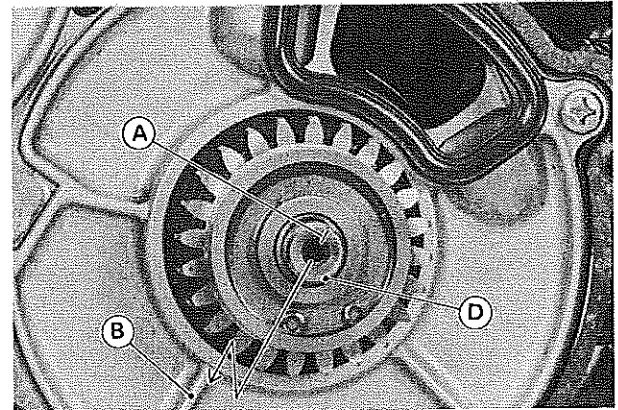

A. Marks
B. Rib

C. Rear Crankshaft
D. Front Crankshaft

- When installing the primary gears, align the gear marks with the crankshaft marks respectively as shown.

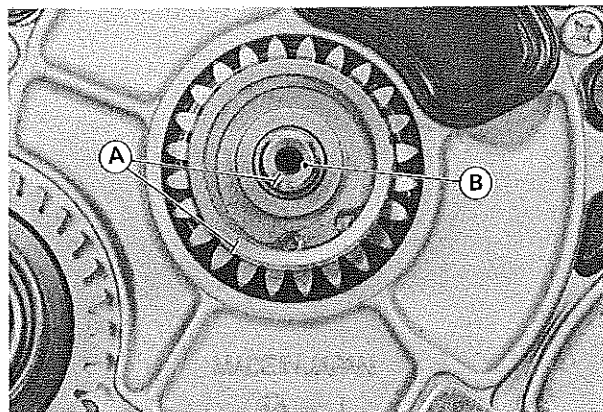

A. Line Marks

B. Crankshaft

- Position the front crankshaft at TDC and the rear crankshaft at BDC.

- Then, the mark on the front crankshaft is up, and the mark on the rear crankshaft down. Besides each mark direction aligns with the rotary valve cover rib line.

- After inserting the two washers, install the clutch gear.
- Finally install the front primary gear with the teeth located outboard.

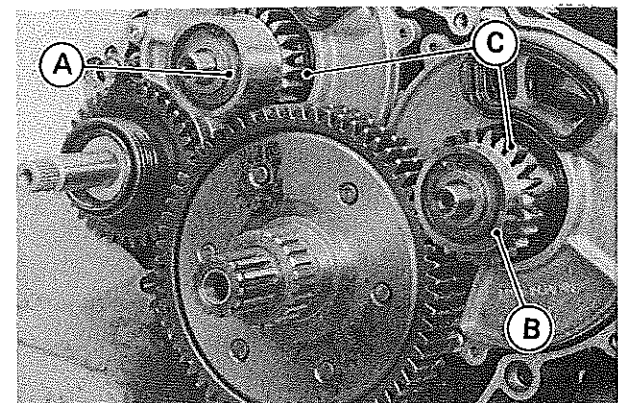

A. Rear Primary Gear
B. Front Primary Gear

C. Gear Teeth

Primary Gear Timing (Righthand View)

The following figure shows the locations among the marks, the primary gears and the clutch gear after correct installation.

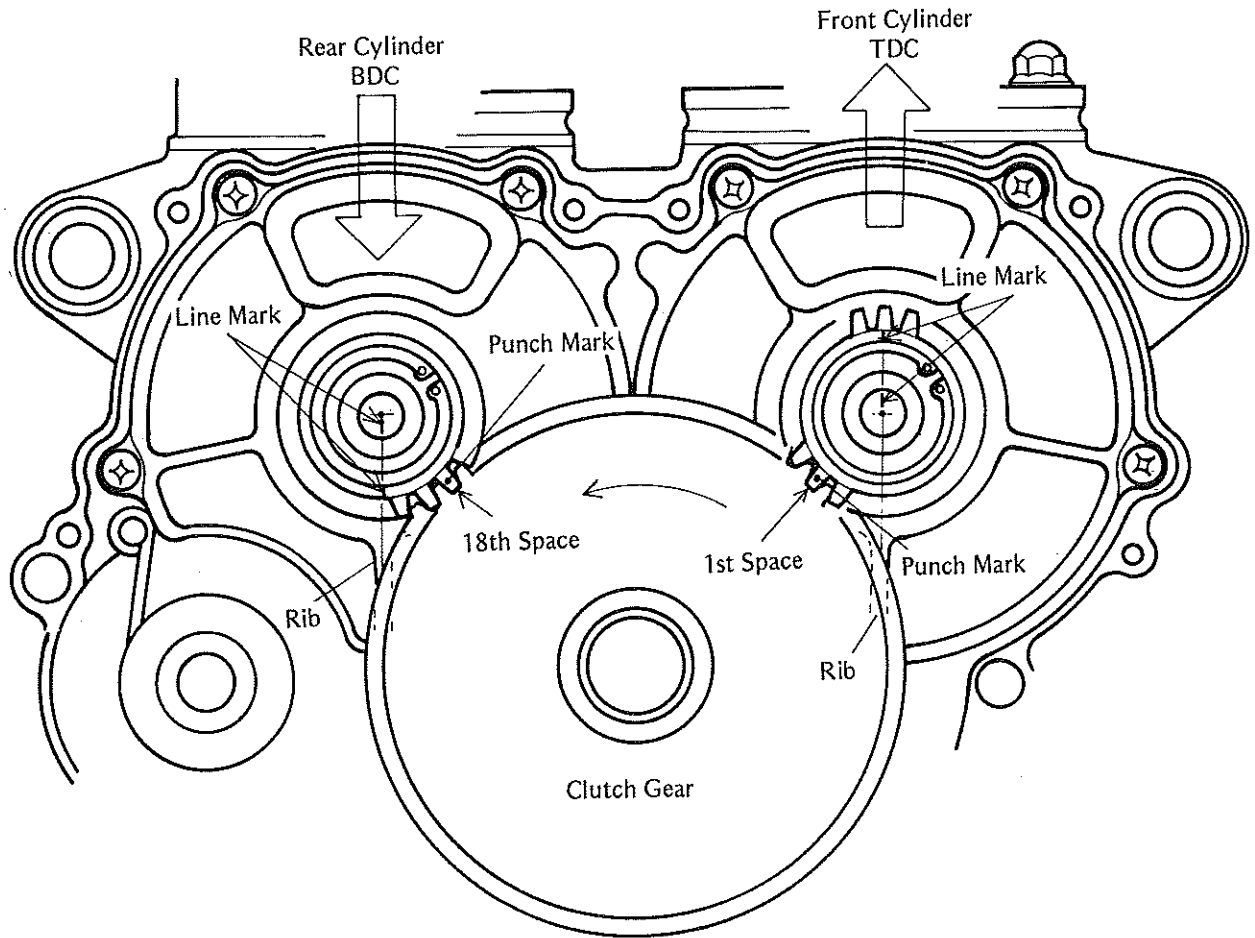

Primary Gear Disassembly

- Remove the primary gear
- Take off the circlip while compressing the retainer boss.

Primary Gear Assembly

- Apply a molybdenum disulfide engine assembly grease to the cam surfaces of the damper cams and primary gears.

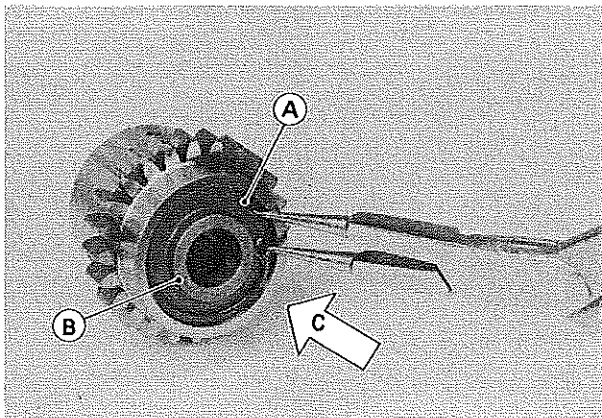

A. Circlip
B. Retainer

C. Press here.

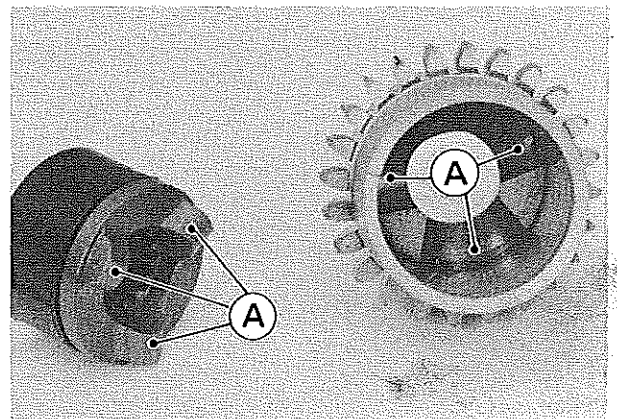

A. Cam Surfaces

5-12 CLUTCH

- Select the washers using the following steps in order to keep the variation in the damper spring load at minimum.
- First, insert two washers **1.2 mm** thick and place the thin springs (4), the thick springs (3) and then the retainer in this order, being careful of the installation direction.

Washer Selection

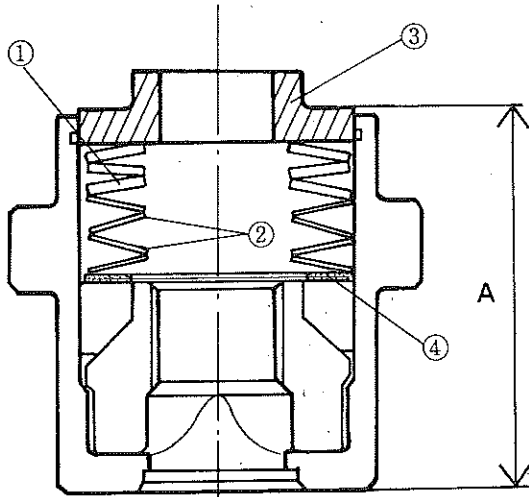

1. Thick Damper Springs
2. Thin Damper Springs
3. Retainer
4. Washer

○ Next, measure the dimension A.

Dimension A

Standard : 50.3 – 50.7 mm

○ Finally, select washers according to the table below and install them.

Washer Selection

Dimension A not less than – less than	Thickness and Nos.
51.5 mm	1.2 mm
51.1 – 51.5 mm	0.8 mm x 2
50.7 – 51.1 mm	0.8 mm + 1.2 mm
50.3 – 50.7 mm (specified dimension)	1.2 mm x 2 (no change required)
49.9 – 50.3 mm	0.8 mm x 2 + 1.2 mm
49.5 – 49.9 mm	0.8 mm + 1.2 mm x 2

Washer Part Nos.

- t0.8 mm : 92022-1616
 t1.2 mm : 92022-213

- Align the damper cam punch mark with one of the primary gear holes spaced equally round the circumference.
- Select a locating hole on the extension of the line mark from among the holes.

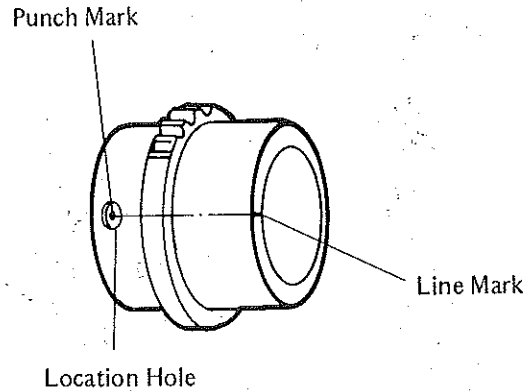

- Install the circlip with the round edge faces in to prevent the circlip from slipping out.
- Fit a new circlip into the groove, while pushing the retainer only enough to install the circlip and no more.

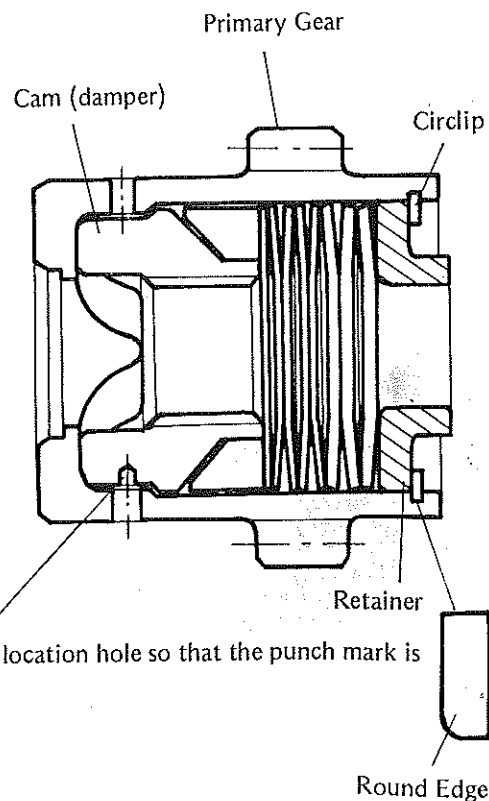

Position the location hole so that the punch mark is visible.

Round Edge

Primary Gear Damper Inspection

- Visually inspect the cam surfaces of the primary gears and the damper cams.
- ★If they are badly worn, replace the primary gears and the damper cams.
- Visually inspect the damper springs for cracks or other damage.
- ★If they are damaged, replace them with new ones.
- Visually inspect the damper shoes.
- ★If the abnormal wear or the exposed base metal is found, replace all the damper shoes.

Primary Gear Damper

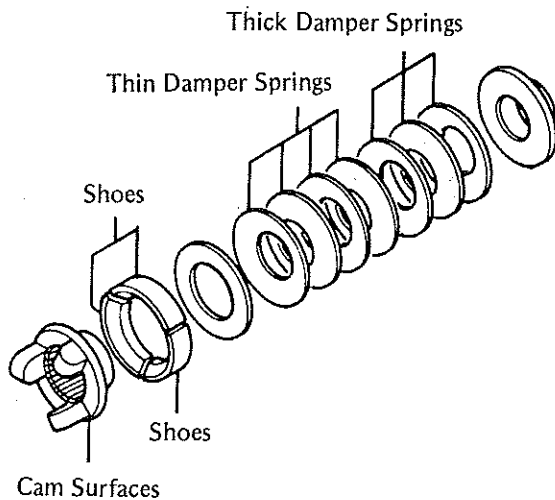

Kickstarter

Kickstarter Removal

- Remove the clutch gear and the primary gears.
- Pull off the kick spring guide.

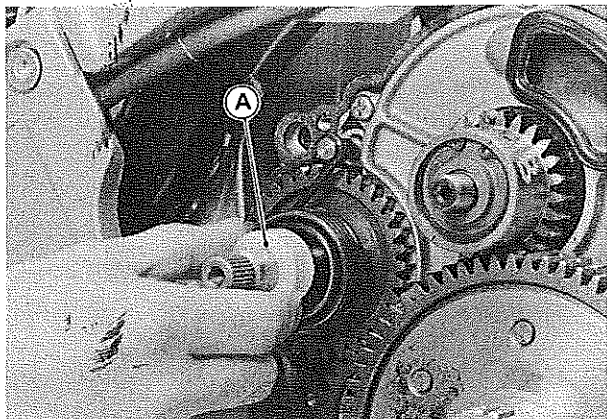

A. Kick Spring Guide

- Remove the kickstarter spring.

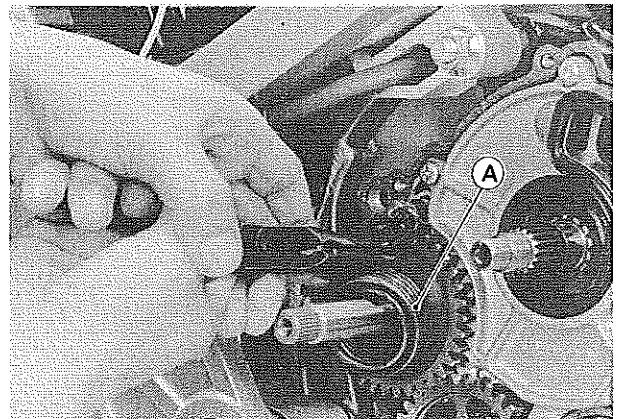

A. Spring

- Remove the kick shaft assembly, twisting it counter-clockwise.

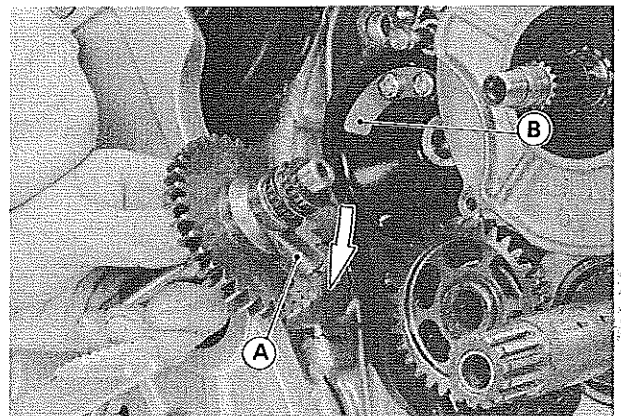

A. Ratchet

B. Kick Guide

- Remove the circlip and pull out the kick idle gear.

Kickstarter Installation

- Apply a little molybdenum disulfide grease to the bearing housing of the kick idle gear.
- Install the idle gear being careful of the installation direction.
- Install the washer, idle washer, and circlip in that order.

5-14 CLUTCH

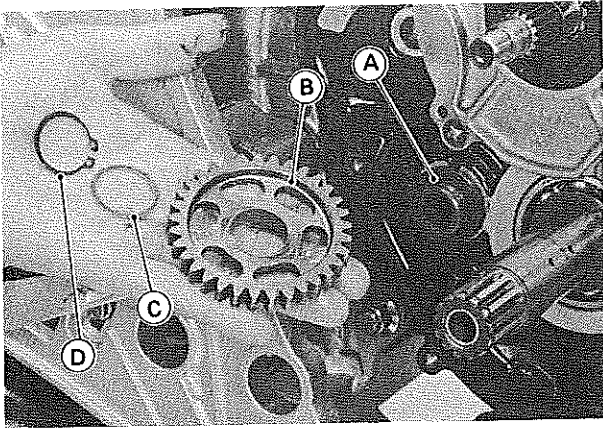

A. Washer
B. Idle Gear

C. Washer
D. Circlip

- With needle nose pliers, insert the end of the kick spring on the pin.

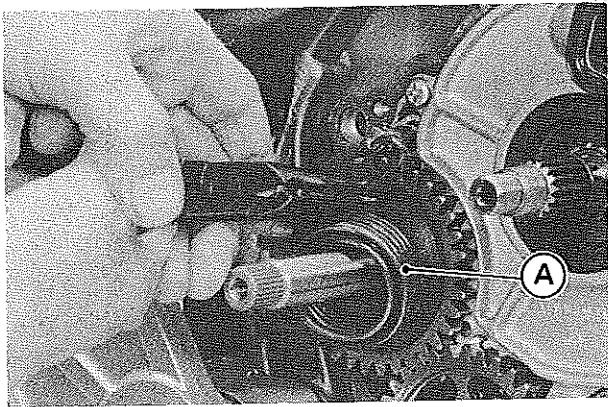

A. Kick Spring

- Push in the kick spring guide completely.

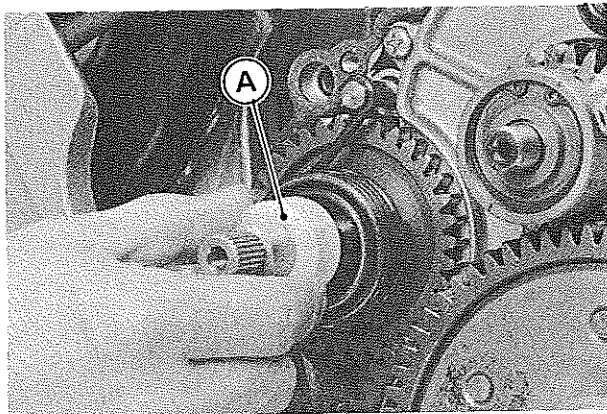

A. Kick Spring Guide

Kickstarter Assembly Notes

NOTE

- When installing the ratchet on the kick shaft, align the ratchet punch mark with the punch mark on the kick shaft.

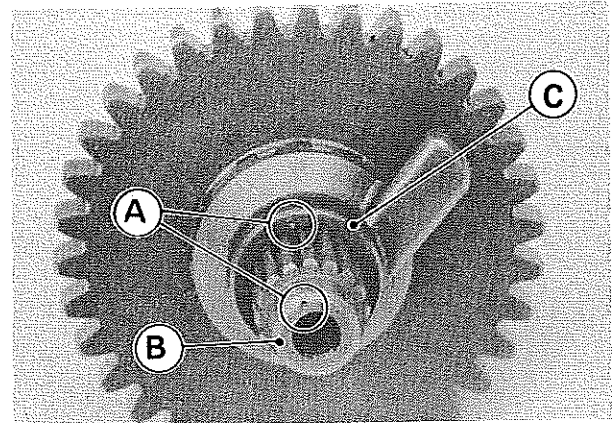

A. Align the marks
B. Kick shaft

C. Ratchet

CAUTION

- Misalignment of the ratchet gear changes the kick spring preload. Light preload could cause mechanism noise, while heavy preload could weaken or break the spring.

Kick Lever Installation

- Install the kick lever so that the pedal is located beside the rear carburetor.
- Make sure the lever does not touch the fuel tank or the right engine cover.

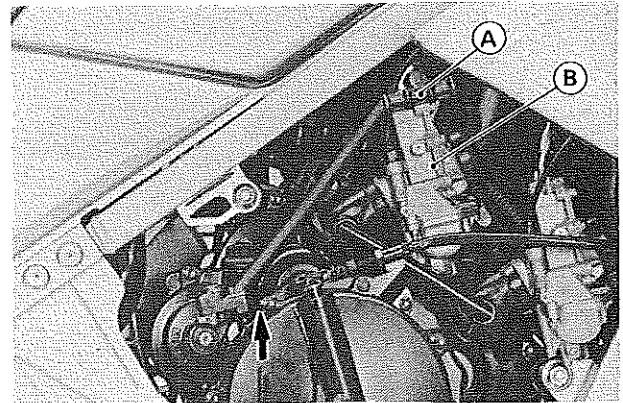

A. Pedal

B. Rear Carburetor

Right Engine Cover

Right Engine Cover Cleaning

- Blow the oil passage clean with compressed air.

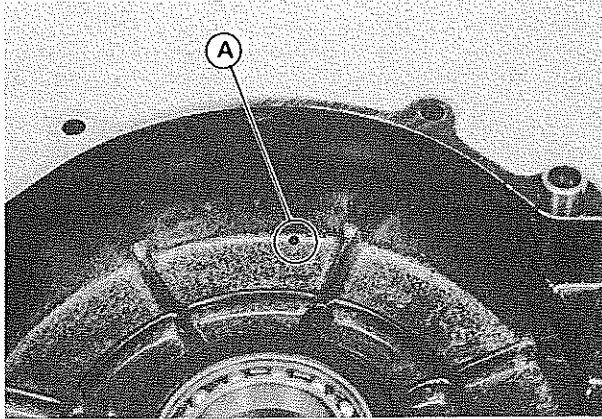

A. Oil Passage

Spring Pin Assembly Note

- Press the new spring pins in the right engine cover so that the grooves face up with the engine unit installed on the frame. The pins supply oil to the primary gear dampers.

CAUTION

- Improper spring pin installation could cause mechanical noise.

Cover Damper Installation

- Position the damper slit as shown.
- Install the damper so that the damper's round edge faces the damper cover.
- If the damper mounting bolts are used ones, apply a non-permanent locking agent to the threads.
- Tighten the damper mounting bolts to the specified torque in the order of index number.

Clutch Damper Installation

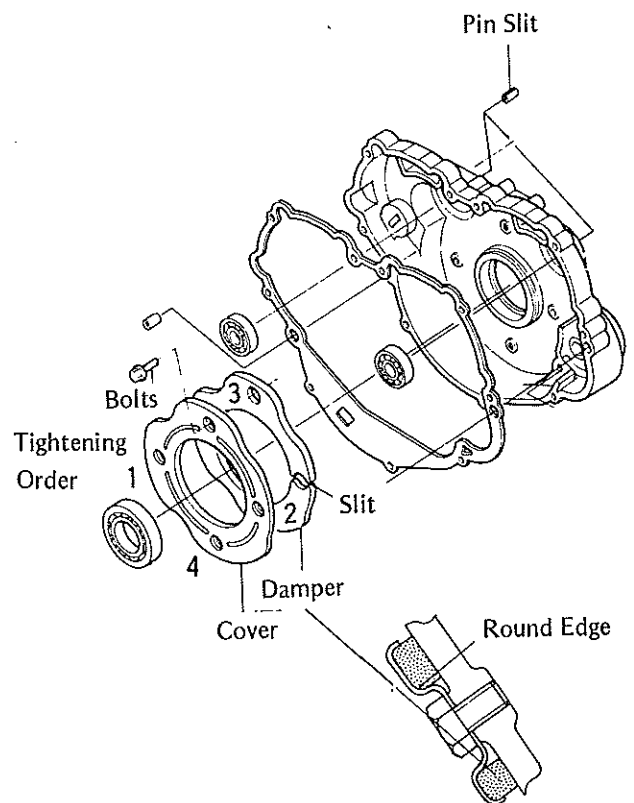

Clutch Cover

Clutch Cover Installation

- Install the clutch cover with the clutch release flat surface faced to the front.

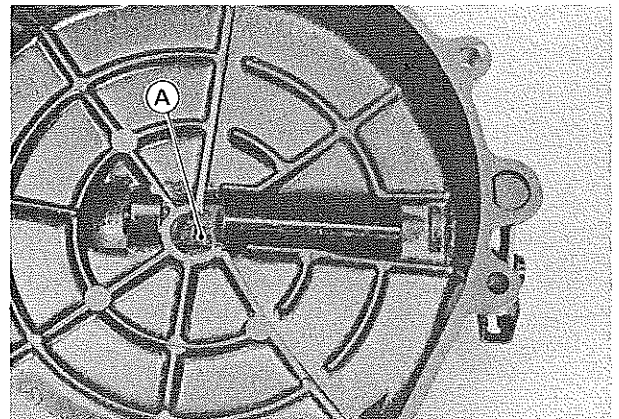

A. Flat Surface

5-16 CLUTCH

Clutch Cable

Clutch Cable Installation

- Run the clutch cable along with the choke cable from the left side of the headpipe, to the bottom of the fork underbracket and to the left of the radiator cap.

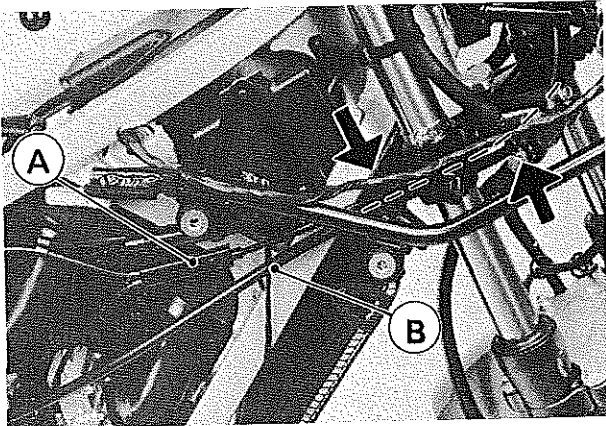
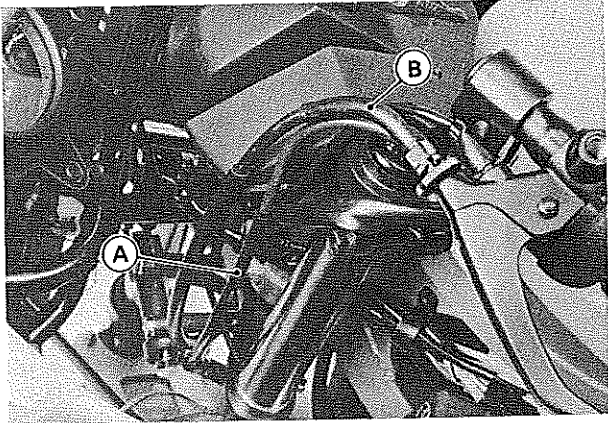

A. Choke Cable

B. Clutch Cable